

2530 2530D
1533 1533D
1530 1530D

高速自动加油曲折缝纫机(大梭)

HIGH SPEED AUTO OILER SINGLE NEEDLE ZIGZAG MACHINE

高速自动加油两同步曲折缝纫机(大梭)

HIGH SPEED AUTO OILER UPPER/LOWER FEED LOCK/STITCH ZIGZAG MACHINE

使用说明
Operation Manual
零件样本
Parts Book

Read safety instructions carefully and understand them before using.
Retain this Instruction Manual for future reference.

感谢您购买本公司的产品。
为了安全地使用，请您在使用之前一定阅读本使用说明书。
另外，请您注意保管本使用说明书，以便随时查阅。

menu

parts breakdown illustration

A. Arm bed components.....	1
B. upper shaft.vertial shaft.taje-up mahanism.....	1
C. swaying needle.Lower shaft. Rotating shuttle shaft mahanism.....	3
D. sewing line adjusted mahanism.....	3
E. lower Feed lifting mechanism.....	5
F. Feed lifting mechanism.....	5
G. top Feed mahanism components.....	7
H. Multi points sewing mechanism.....	7
I. Lubrication mechanism.....	9
J. Accessories.....	9

operation instruction

one、 item of all components.....	11
two、 sewing machine specification.....	12
three、 installation.....	12
1. oil disk.....	12
2. knee-control component.....	12
3. rubber cushions.....	13
4. Triangle Shock Pad.....	13
5. ear Shock Pad.....	13
6. knee lifter complying bar.....	13
7. The machine head.....	13
8. Pillow of the head.....	13
9. U type belt cover.....	13
10. C type belt cover.....	13
11. Triangle belt cover.....	13
12. D type belt cover.....	13
Four、 adjust sewing machine.....	14
1. Installing the needle.....	14
2. removing the cap and adjust the tension.....	14
3. Winding the lower thread.....	14
4. Threading the upper thread and adjust.....	15
5. adjusting presser foot pressure.....	15
6. adjusting the stitch length.....	15
7. adjusting the height of feed dog and Tilt.....	15
五、故障原因及对策.....	16

A. 本体外观

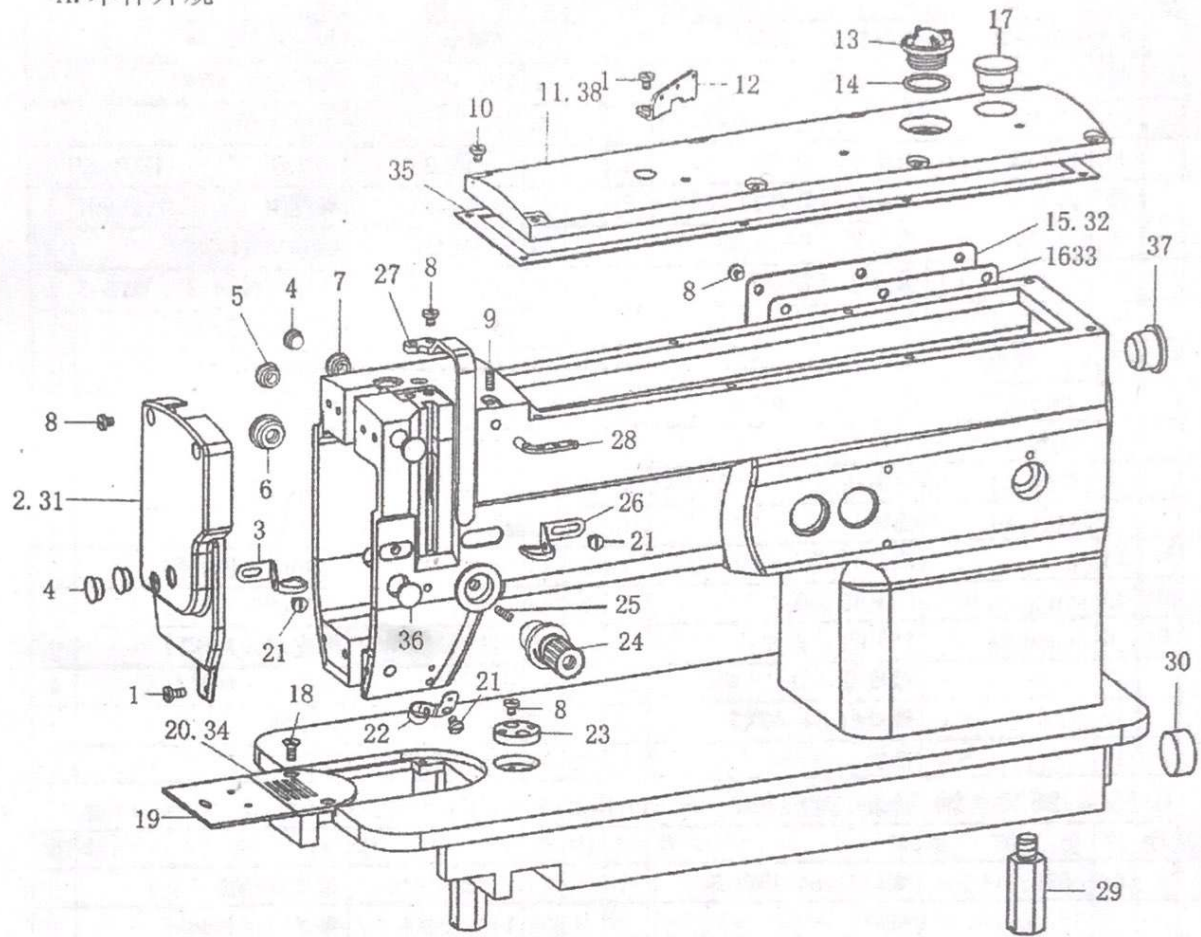

B. 上轴. 竖轴. 挑线机构

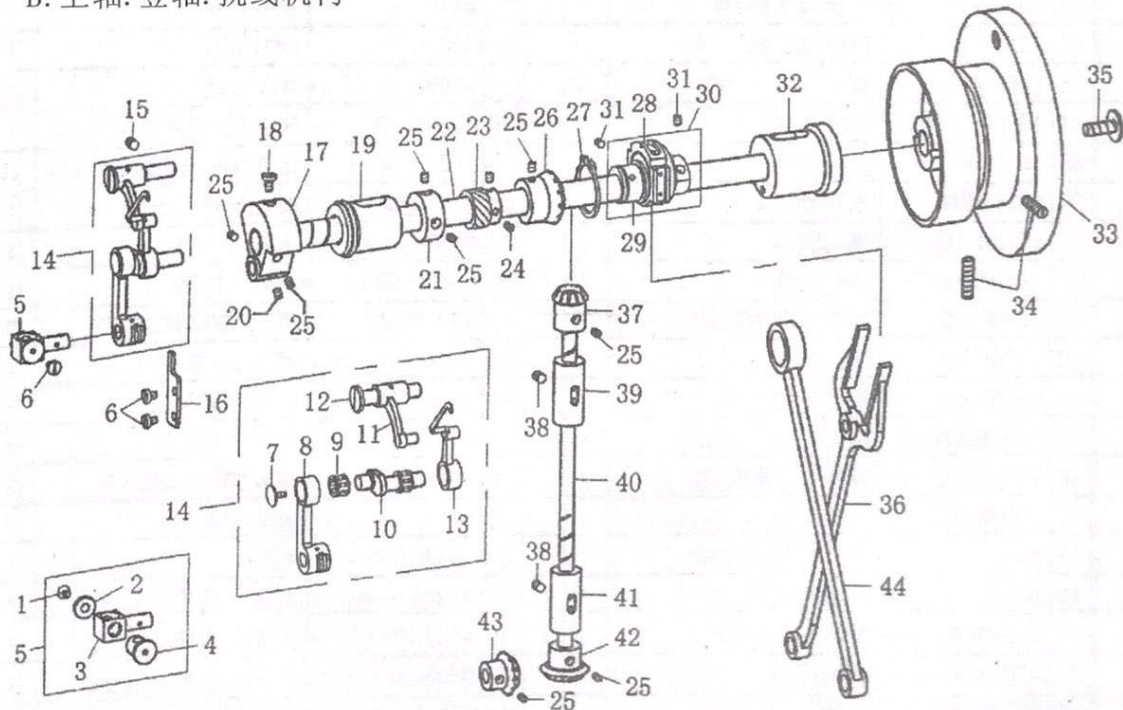

A. Arm bed components

(Memo:#01 for 1530 #02 for 2530)

Memo	Ref No.	Part NO.	item	Amt Req	Memo	Ref No.	Part NO.	item	Ref No.
	01	Y43-D8X6	screw 11/64-40X5	3	1	20	1530A-20	sliding plate complete	1
01	02	1530A-2	fale plate	1		21	Y35-D7X7	screw 9/64-40X7	3
	03	1530A-3	threadcam DY2-29	1		22	#28	threadcam	1
	04	P11.8X5	rubber plug (D=11)	4		23	1530A-23	holder DY2-22	1
	05	p10.8x4	rubber plug (D=10)	3		24	1530A-24	Cramping group DY2-901	1
	06	P15.8X6	rubber plug (D=14.5)	1		25	Y59-D0X7	scew 15/64-28X7	3
	07	P8.8X5	rubber plug (D=8)	1		26	1530A-26	threadcam	1
	08	Y43-D7X7	screw 11/64-40X7	8		27	1530A-27	stitch-sfaff shield	1
	09	Y43-D0X6	screw 11/64-40X6	8		28	#19	three-eye finger	1
	10	Y43-D7X9	screw 11/64-40X9	8		29	1530A-29	bed leg	3
	11	1530A-11	upper corer	1		30	P24X7	rubber plug (D=23.5)	1
	12	1530A-12	threadcam 33A-35	1	02	31	2530A-31	fale plate	1
	13	1530A-13	oil screen complete	1	02	32	2530A-32	side plate	1
	14	0R-18	O-type ring	1	02	33	2530A-33	washer	1
01	15	1530A-15	side plate	1	02	34	2530A-34	needle plate	1
01	16	1530A-16	Washer	1		35	P13	rubber plug (D=12)	1
	17	P18.5	rubber plug	1		36	P8	rubber plug (D=7)	1
	18	#263	scew 11/64-40X7	2		37	P20X4	rubber plug	1
	19	1530A-19	sliding plate	1	02	38	2350A-38	upper cover	1

B. 1530, 2530 upper shaft, vertial shaft, taje-up machanism. (Memo:#01 for 1530 #02 for 2530)

Memo	Ref No.	Part NO.	item	Amt Req	Memo	Ref No.	Part NO.	item	Ref No.
	01	1530B-1	scew 11/64-40X3.5	1		23	1530B-23	needle sewing drive gear(upper)	1
	02	1530B-2	washer	1		24	Y43-SD0X4	screw 11/64-40X4	2
	03	1530B-3	needle crank	1		25	Y63-SD0X6	screw 1/4-40X6	10
	04	1530B-4	needle crank	1		26	#116	bevel gear	1
	05	1530B-5	needle crank complete	(1		27	S26	C thrust collar	1
	06	Y43-D8X6	screw 11/64-40X6	3		28	#129	Feed "Y" connecting asm	1
	07	1530B-7	screw	1		29	1530B-29	eccentric cam DY4-904B	1
	08	1530B-8	needle bar crank	1		30	1530B-30	eccentric cam complete DY4-904	(1
	09	08X12X08	needle bearing	2		31	Y59-D0X7	screw 15/64-28X7	1
	10	1530B-10	thread take-up crank	1		32	#133	main shaft thrust collar (right)	1
	11	1530B-11	take-up thread con	1		33	1530B-33	hand wheel 33B-69	1
	12	1530B-12	shaft	1		34	Y59-D0X15	screw 15/64-28X15	2
	13	1530B-13	take-up thread	1		35	#136	screw 11/32-28X13	1
	14	1530B-14	take-up thread complete	(1		36	1530B-36	feed holder	1
	15	Y59-D0X15	screw 15/64-28X15	1		37	#117	vertial shaft upper gear	1
	16	1530B-16	rail	1		38	Y59-D0X11	screw 15/64-28X11	2
	17	1530B-17	needle bar crank	1		39	#119	vertial shaft thrust collar	1
	18	#105	screw 9/32-28X10	1		40	1530B-40	vertial shaft	1
	19	#103	front bushing	1		41	#120A	vertial shaft thrust collar D=17.5	1
	20	Y63-D0X5	screw 1/4-40X5	1		42	#124	vertial shaft lower gear	1
	21	#102	upper shaft retainer	1		43	#125	lower shaft right gear	1
	22	1530B-22	arm shaft	1		44	1530B-44	toothed connecting bar 33B-74	1

C. 摆针. 下轴. 梭轴机构

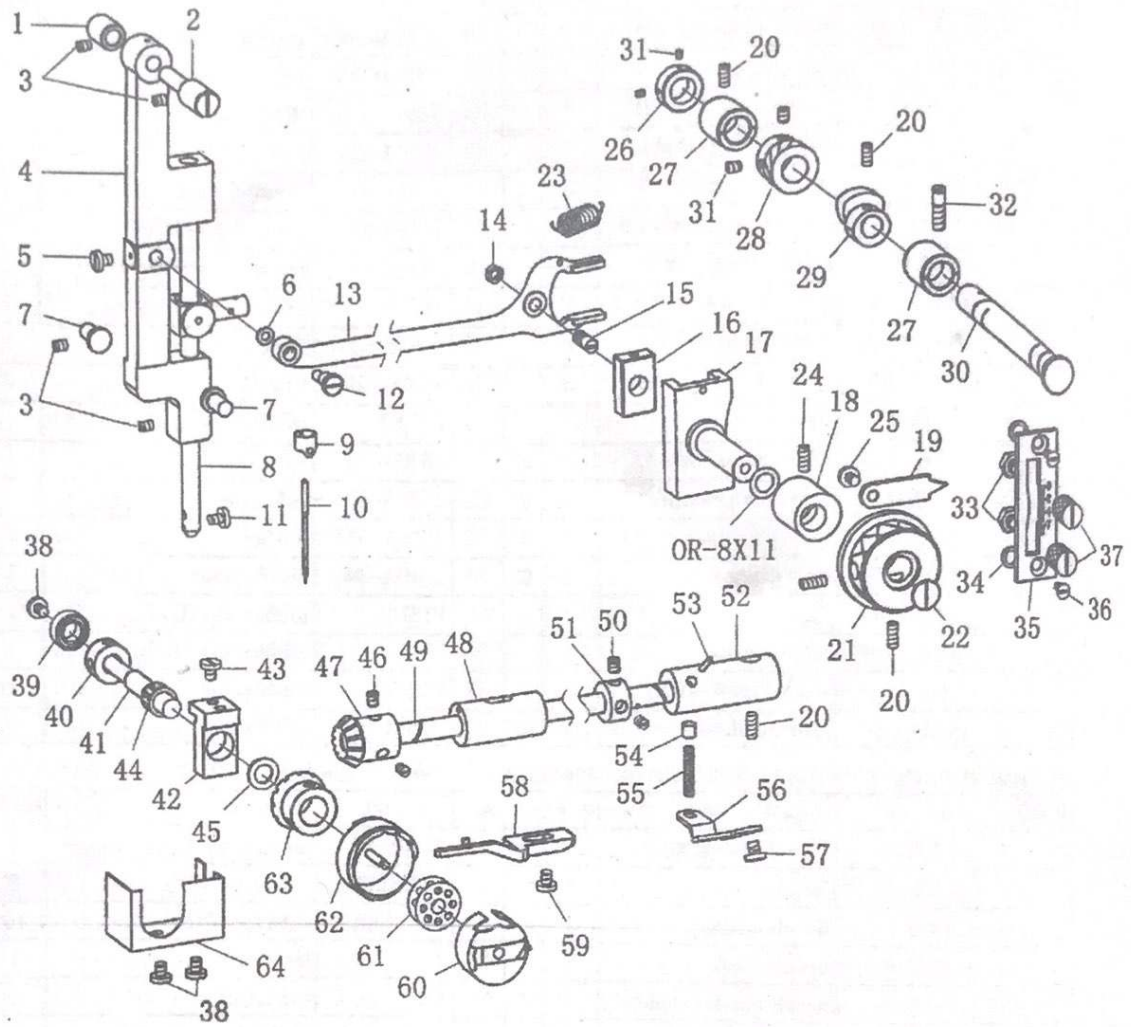

D. 缝目调节机构

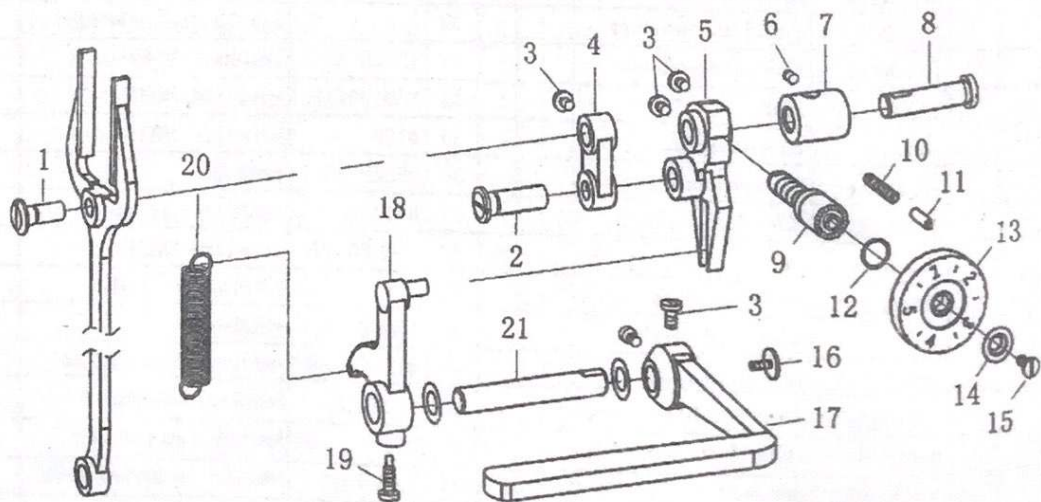

C. 1530. 2530 swaying needle. Lower shaft. Rotating shuttle shaft machanism (Memo:#01 for 1530 #02 for 2530)

Memo	Ref No.	Part NO.	item	Amt Req	Memo	Ref No.	Part NO.	item	Ref No.
	01	1530C-1	shaft of swaying rack screw	1		33	1530C-33	Nut 11/64-40X3	2
	02	1530C-2	shaft of swaying rack	1		34	1530C-34	washer DY8-201	2
	03	LW-M4X4	screw M4-0.75X4	6		35	1530C-35	sewing width showing plate	1
	04	1530C-4	swaying rack of needle bar	1		36	1530C-36	screw 11/64-40X10	2
	05	Y43-D8X6	screw 11/64-40X6	1		37	1530C-37	screw 11/64-40	2
	06	W5X10X1	washer W5X10X1	1		38	Y35-D6X6	screw 9/64-40X6	3
	07	1530C-7	swaying rack bush	2		39	696ZZ	shaft696	1
	08	1530C-8	needle bar	1		40	1530C-40	retainer of rotating shuttle shaft	1
	09	91C-38	thread finger	1		41	1530C-41	rotating shuttle shaft	1
	10	DPX5	needle bar	1		42	1530C-42	locating plate rotating shuttle	1
	11	Y3144-D4X4.5	screw 1/8-44X4.5	1		43	LT-M4X10	screw M4-0.7X10	2
	12	1530C-12	eccentric pin	1		44	08X12X08	needle bearing	1
	13	1530C-13	fork (lower)	1		45	W8X16X1	washer W8	(1
	14	Y71-LM11X4	Nut 9/32-28X4	1		46	Y63-SDOX6	screw 1/4-40X6	2
	15	1530C-15	shaft of fork (lower)	1		47	1530C-47	lower shaft gear	1
	16	1530C-16	sliding block	1		48	#119	left sleeve of lower shaft D=17	1
	17	1530C-17	sliding block support	1		49	1530C-49	hook driving shaft	1
	18	1530C-18	sleeve DY8-155	1		50	Y59-D0X5	screw 15/64-28X5	2
	19	1530C-19	stitch width pointer	1		51	#122	lower shaft retainer	1
	20	Y59-D0X7	screw 15/64-28X7	4		52	1530C-52	hook driving shaft thrust collar(right)	1
	21	1530C-21	stitch width knob	1		53	1530C-53	oil tube	1
	22	Y4728-D14X8	screw 3/16-28X8	1		54	1530C-54	screw 15/64-28X5	1
	23	1530C-23	spring	1		55	#160	spring	1
	24	Y59-D0X11	screw 15/64-28X11	1		56	1530C-56	frame	1
	25	#263	screw 11/64-40X7	1		57	Y59-D8X10	screw 15/64-28X10	1
	26	1530C-26	retainer of swaying needle shaft	1		58	1530C-58	rotating book position finger	1
	27	1530C-27	sleeve of swaying needle	2		59	Y43-D9X9	screw 11/64-40X9	1
	28	1530C-28	swaying needle gear (lower)	1		60	1530C-60	bobbin	1
	29	1530C-29	eccentric cam	1		61	1530C-61	bobbin case	1
	30	1530C-30	swaying needle shaft	1		62	1530C-62	hook	1
	31	Y43-SDOX4	screw 11/64-40X4	4		63	1530C-63	gear	1
	32	1530C-32	screw 15/64-28	4		64	1530C-64	butter box	1

D. 1530. 2530 sewing line adjusted machanism (Memo:#01 for 1530 #02 for 2530)

Memo	Ref No.	Part NO.	item	Amt Req	Memo	Ref No.	Part NO.	item	Ref No.
	01	1530D-1	shaft	1		12	OR-14	O ring	1
	02	#152	feed regulaotor screw	1		13	1530D-13	dial number	1
	03	Y59-D8X10	screw 15/64-28X10	5		14	1530D-14	washer	1
	04	1530D-4	stitch adjustment rod	1		15	Y4728-D8X15	screw 3/16-28X15	5
	05	1530D-5	feed regulator	1		16	Y4728-D14X8	screw 3/16-28X8	5
	06	Y59-D0X11	screw 15/64-28X11	1		17	#167	bartacking lever	1
	07	#158S	feed regulator bush	1		18	#906	bartacking srank	1
	08	#159	feed regulator hinge pin	1		19	#171	screw 15/64-28X10	1
	09	1530D-9	feed regulator screw	1		20	#172	spring	1
	10	#160	spring for stopper pin	1		21	#169	bartaking lever shaft	1
	11	#162	stpper pin	1					1

E. 下送布机构

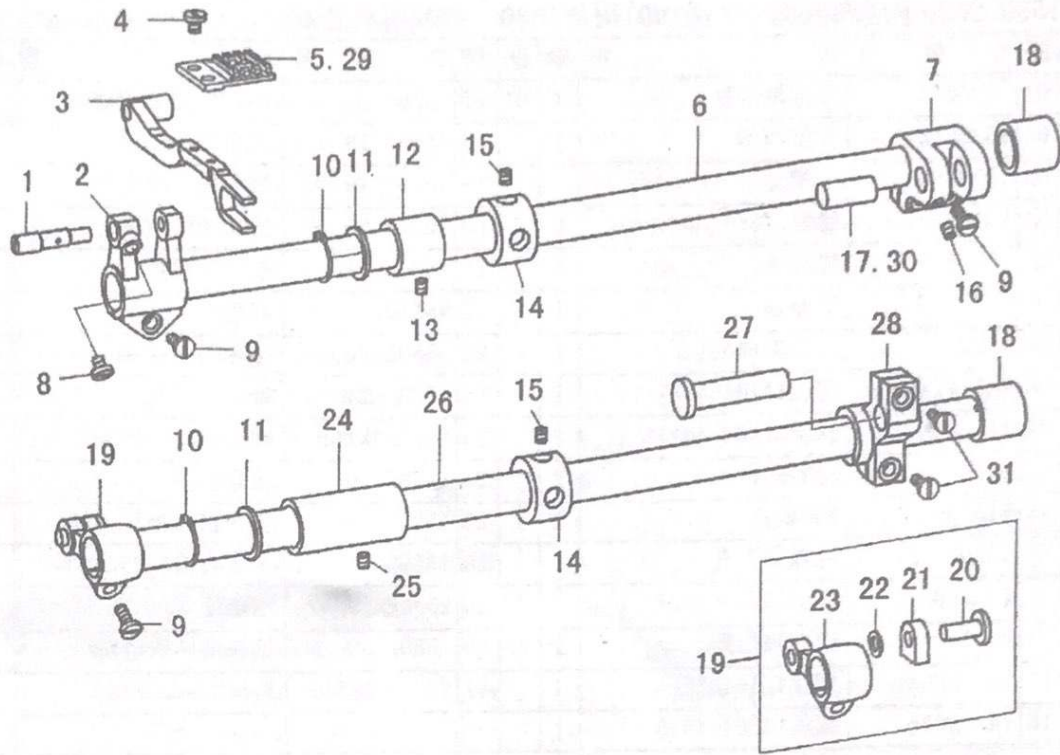

F. 抬押机构

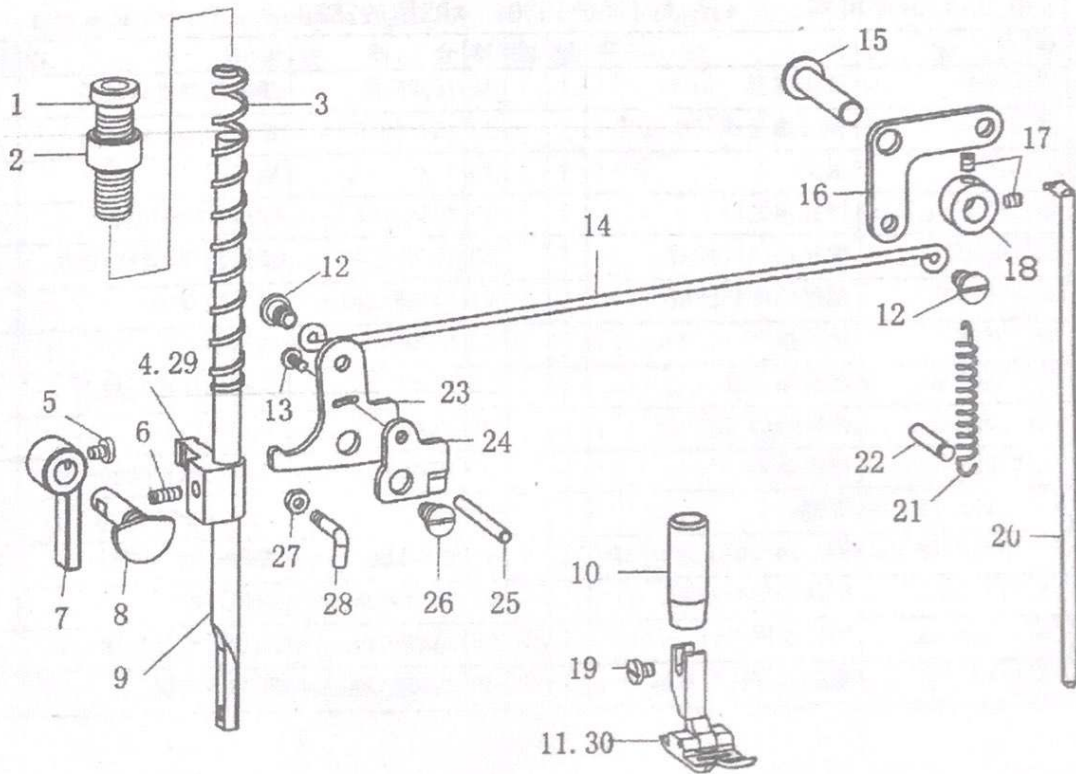

E. 1530. 2530 lower Feed mechanism components

(Memo:#01 for 1530 #02 for 2530)

Memo	Ref No.	Part NO.	item	Amt Req	Memo	Ref No.	Part NO.	item	Ref No.
	01	1530E-1	feed holder shaft	1	01	17	#226	shaft	1
	02	1530E-2	feed crank	1		18	1530E-18	feed driving shaft bushing(right)	2
	03	1530E-3	feed holder shaft	1		19	1530E-19	feed crank group	(1
	04	Y3144-D5X6	screw 1/8-44X6	2		20	1530E-20	moving crank group	1
01	05	1530E-5	feed dog	1		21	1530E-21	moving crank	1
	06	1530E-6	material feeding shaft	1		22	W6X10	washer W6	1
	07	#222	feed driving shaft crank (right)	1		23	1530E-23	feed crank group	1
	08	Y43-D7X7	screw 11/64-40X7	1		24	1530E-24	feed lifting shaft bushing(left)	1
	09	Y43-D8X13	screw 11/64-40X13	3		25	Y59-D0X11	screw 15/64-28X11	1
	10	S-15	s type	2		26	1530E-26	toothed shaft	1
	11	W15X20	washer W15	2		27	1530E-27	feed lifting shaft bushing(left)	1
	12	1530E-12	feed rocker shaft(left)	1		28	1530E-28	feed lifting shaft crank (right)	1
	13	Y59-D0X7	screw 15/64-28X7	1	02	29	2530E-29	material feeding shaft	1
	14	#211	thrust collar	2	02	30	2530E-30	shaft	1
	15	Y63-SD0X6	screw 1/4-40X6	4		31	Y4728-D8X15	screw 3/16-28X15	2
	16	Y43-D0X6	screw 11/64-40X6	1					

F. 1530. 2530 Feed lifting mechanism

(Memo:#01 for 1530 #02 for 2530)

Memo	Ref No.	Part NO.	item	Amt Req	Memo	Ref No.	Part NO.	item	Ref No.
	01	#184	screw	1		16	1530F16	lever (right)	1
	02	42C-4	nut 10-143	1		17	Y59-D0X5	screw 15/64-28X5	2
	03	#187	spring	1		18	#122	washer	1
01	04	1530F-4	guide for presser bar	1		19	Y35-D7X7	screw 9/64-40X7	1
	05	Y43-D7X7	screw 11/64-40X7	1		20	1530F-20	connecting rod L=200	1
	06	Y59-D0X7	screw 15/64-28X7	1		21	1530F-21	spring	1
	07	1530F-7	presser foot lift bar	1		22	1530F-22	Pin	1
	08	1530F-8	presser foot lift	1		23	1530F-23	lever (left)	1
	09	1530F-9	presser bar	1		24	1530F-24	thread releasing cam	1
	10	#202	dushing for presser bar	1		25	1530F-25	thread releasing lever	1
01	11	1530F-11	presser	1		26	1530F-26	SM5/64-28X7.5	
	12	1530F-12	screw 3/16-28X5 341F-25	2		27	Y35-LM6X3	Nut 9/64-40X3	1
	13	Y43-D9X7	screw 11/64-40X7	1		28	1530F-28	thread guide	1
	14	1530F-14	knee lifter drawing bar	1	02	29	2530F-29	Guide for presser bar	1
	15	1530F-15	knee lifter drawing lifter bar	1	02	30	2530F-30	presser foot	1

G. 2530上送布机构

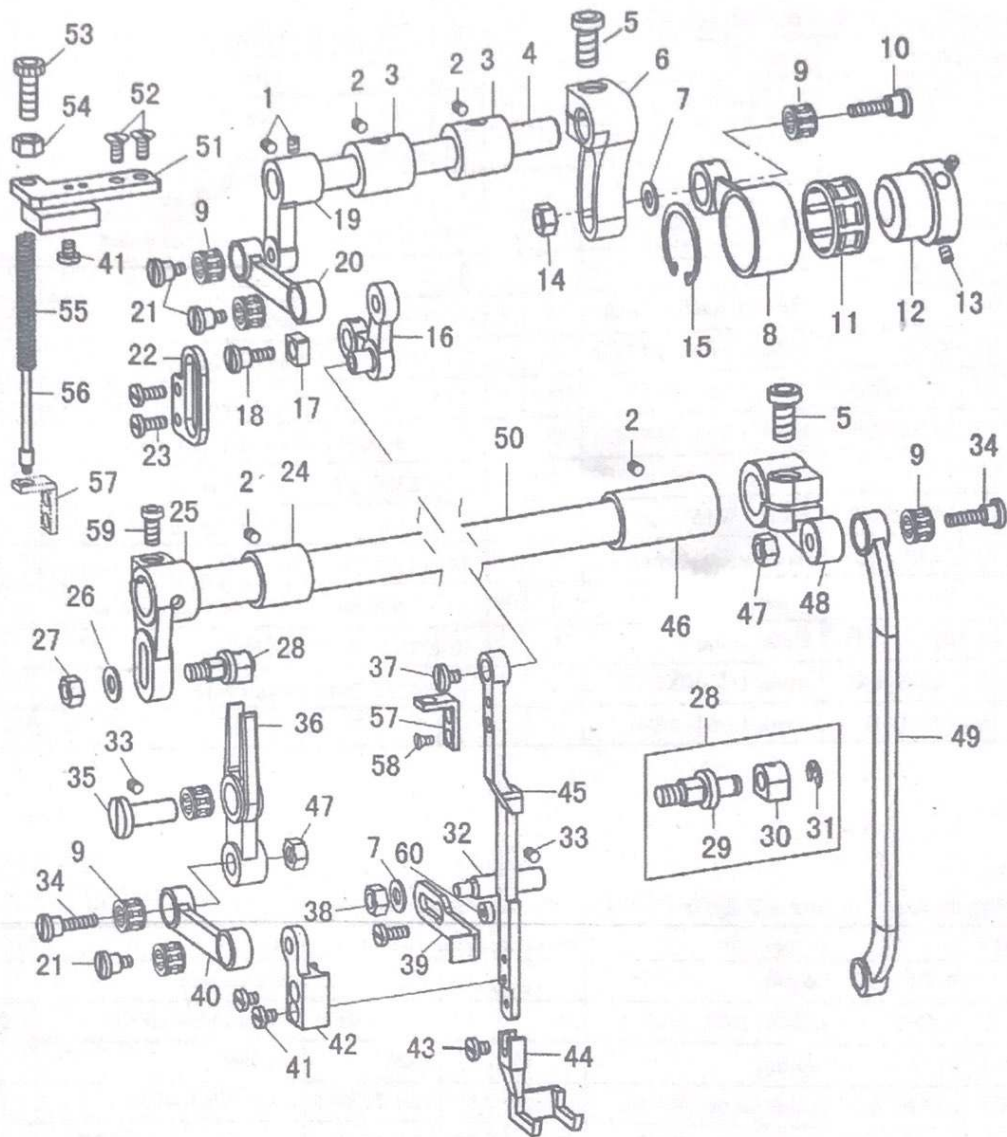

H. 多点摆针机构

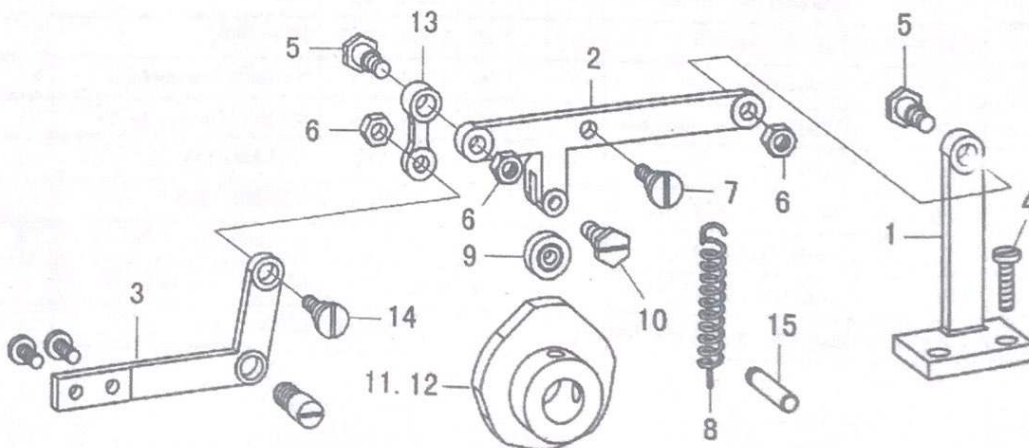

G. 2530 top Feed mechanism components

(Memo:#01 for 1530 #02 for 2530)

Memo	Ref No.	Part NO.	item	Amt Req	Memo	Ref No.	Part NO.	item	Ref No.
	1	LW-M6X5	screw M6X5	2		31	E-4	E-4 type	1
	2	Y43-D0X6	screw 11/64-40X6	4		32	2530G-32	shin	1
	3	2530G-3	bushing GY8-155	2		33	Y59-D0X7	screw 15/64-28X7	2
	4	2530G-4	presser foot lift shaft	1		34	2530G-34	screw 1/4-40X16 37E-34	2
	5	LT-M6X20	screw M6X20	2		35	2530G-35	Pin DY8-208	1
	6	2530G-6	link adjusting crank	1		36	640E-63	fork lever 37E-36	1
	7	W6X12	washer W6	2		37	Y4728-D12X7	3/16-28X7 810-165	1
	8	2530G-8	link complete	1		38	Y59-LM9X3	Nut 15/64-28X3	1
	9	8X12X8	needle bearing	6		39	2530G-39	presser plate	1
	10	2530G-10	screw M6	1		40	2530G-40	link of walking foot	1
	11	24X28X13	needle bearing	1		41	Y35-D6X6	Nut 9/64-X6	2
	12	2530G-12	eccontic cam	1		42	2530G-42	holder for walking foot bar	1
	13	Y63-SD0X6	screw 1/4-40X6	2		43	Y35-D7X7	screw 9/64-40X7	1
	14	KM10X6-M6	Nut M6	1		44	2530G-44	walking foot	1
	15	S-24	S-24 type	1		45	2530G-45	walking foot lever	1
	16	2530G-16	Outer plate suspension support	1		46	640E-46	rear bushing	1
	17	2530G-17	block	1		47	Y63-LM10X5	Nut 1/4-40X5	2
	18	2530G-18	screw 3/16-28X7	1		48	2530G-48	pear crank	1
	19	2530G-19	crank	1		49	2530G-49	link of walking foot	1
	20	2530G-20	feed crank connecting rool 37E-20	1		50	640E-43	presser foot sewing shaft L=360	1
	21	2530G-21	screw 1/4-40X6 37E-21	3		51	2530G-51	guide plate	1
	22	2530G-22	set plate	1		52	#263	screw 11/64-40X7	2
	23	Y43-D7X7	screw 11/64-40X7	2		53	2530G-53	screw DY8-151	1
	24	2530G-24	front bushing	1		54	Y71-LM11X4	Nut 9/32-28X4L	1
	25	640E-57	pear crank	1		55	2530G-55	spring DY8-170	1
	26	W6.5X13	washer W6.5	1		56	2530G-56	guidepin DY8-171	1
	27	Y6324-LM10X5	nut 1/4-24X5	1		57	2530G-57	set plate	1
	28	2530G-28	crank shaft complete	(1		58	#255	screw 9/64-40X7	2
	29	2530G-29	crank shaf	1		59	YT-M6X14	screw M6X14	1
	30	2530G-30	crank pin	1					

H. Multi points sewing mechanism

(Memo:#03 for 3 points #04 for 4 points)

Memo	Ref No.	Part NO.	item	Amt Req	Memo	Ref No.	Part NO.	item	Ref No.
	01	1534H-1	wheel lock support	1		08	1534H-8	spring	1
	02	1534H-2	wheel rod	1		09	624ZZ	shaft	1
	03	1534H-3	connecting bar	1		10	91C-9	screw M4	1
	04	LT-M6X12	screw M6X12	2	03	11	1533H-11	3 points sewing eccentric team	1
	05	1534H-5	Nut 3/16-32 78L2-21-4	2	04	12	1534H-12	4 points sewing eccentric team	1
	06	Y4732-LM8X4	Nut 3/16-32X4	3		13	1534H-13	active bar 78L2-21-3	1
	07	#188-1	screw 3/16-28	1		14	1534H-14	screw 3/16-32 #267	1

I. 供油机构

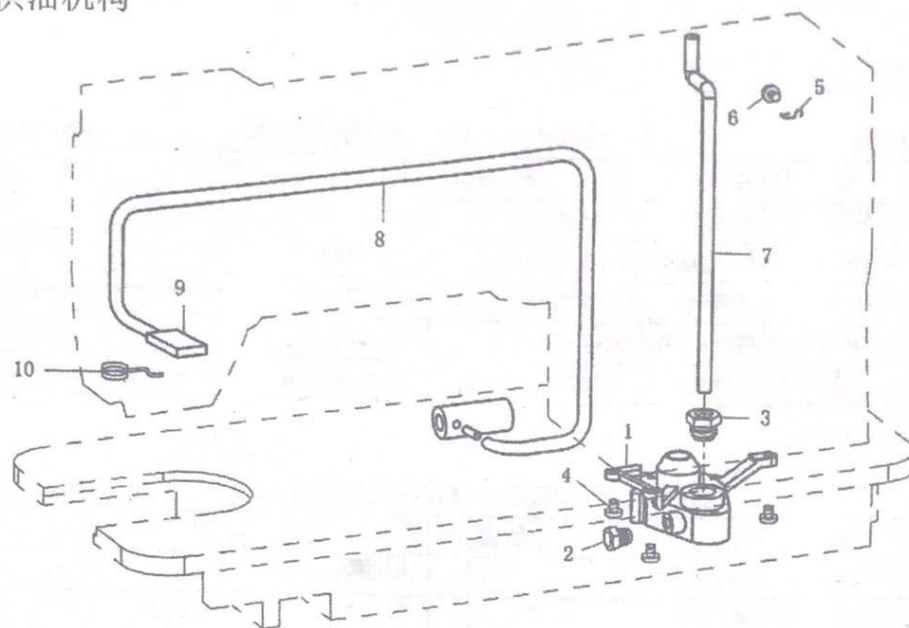

J. 附件

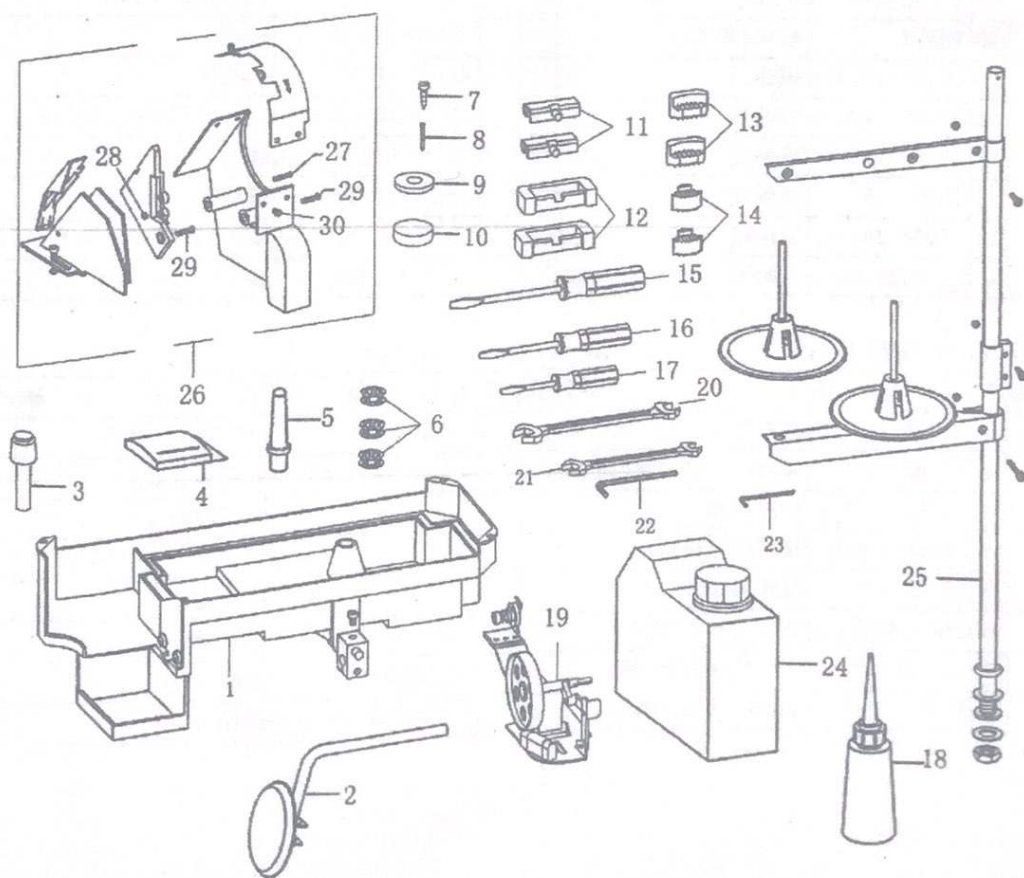

I. Lubrication mechanism

(Memo:#01 for 1530 #02 for 2530)

Memo	Ref No.	Part NO.	item	Amt Req	Memo	Ref No.	Part NO.	item	Ref No.
	01	1530J-1	oil pump body	1		06	1530J-6	Y43-D8X6	1
	02	1530J-2	screw 11/32-28 G-52	1		07	1530J-7	oil pipe for arm shaft	1
	03	1530J-3	screw 11/32-28 G53	1		08	1530J-8	oil returning pipe	1
	04	Y43-D8X13	screw 11/64-40X13	3		09	1530J-9	flet pouch for return oil filter	1
	05	1530J-5	spring for oil pipe	1		10	1530J-10	spring for oil felt	1

J. Accessories

(Memo:#01 for 1530 #02 for 2530)

Memo	Ref No.	Part NO.	item	Amt Req	Memo	Ref No.	Part NO.	item	Ref No.
	01	1530K-1	oil reseroir complete	1		16		screwdriver(M)	1
	02	1530K-2	knee lift complete	1		17		screwdriver(S)	1
	03	1530K-3	knee lifter prop bar	1		18		oiler	1
	04	DPX5	needle	4		19		threadwinding component	1
	05	#811	machine head pole	1		20		spander 12X14	1
	06	1530C-61	bobbin	3		21		spander 10X12	1
	07	M5. 5X25	screw	4		22		Allen wrench 5mm	1
	08		nail	4		23		Allen wrench 2mm	1
	09	W6X12	washer W6X12	4		24	1530K-20	oie cam	1
	10	1530K-10	magnet	1		25	FP-2L	thread stand	1
	11	1530K-11	machine hinge plateasm	2		26	1530K-22	belt coverasm	1
	12	1530K-12	washer (big)	2		27	YT-M4X18	screw M4X18	1
	13	1530K-13	washer (middle)	2		28	LM7X3-M4	Nut M4	1
	14	1530K-14	washer(small)	2		29	Y59-D8X10	screw 15/64-28X10	2
	15		screwdriver(L)	1		30	Y43-D8X6	screw 11/64-40X6	6

1530K-1:Oil reseroit

Memo:#01 for 1530 #02 for 2530

Memo	Ref No.	Part NO.	item	Amt Req	Memo	Ref No.	Part NO.	item	Ref No.
	1	1530K-1-1	oil reseroir	1		9	E-9	E9 type	1
	2	LT-M6X12	screw M6X12	2		10	1530K-1-10	washer	1
	3	1530K-1-3	hinge pin	1		11	1530K-1-11	washer 8X15	1
	4	1530K-1-4	spring	1		12	1530K-1-12	screw SM5/16-28	1
	5	1530K-1-5	frame	1		13	1530K-1-13	oil pam	1
	6	Y59-LM10X4	Nut 15/64-28X4	2		14	YT-M5X12	screw M5X12	2
	7	Y59-D0X25	screw 15/64-28X25	2		15	LM8X3-M5	Nut M5X3	2
	8	#171	15/64-28X15 side 9	1		16	W5X10	washer W5X10	2

一、各部件名称 arm bed components

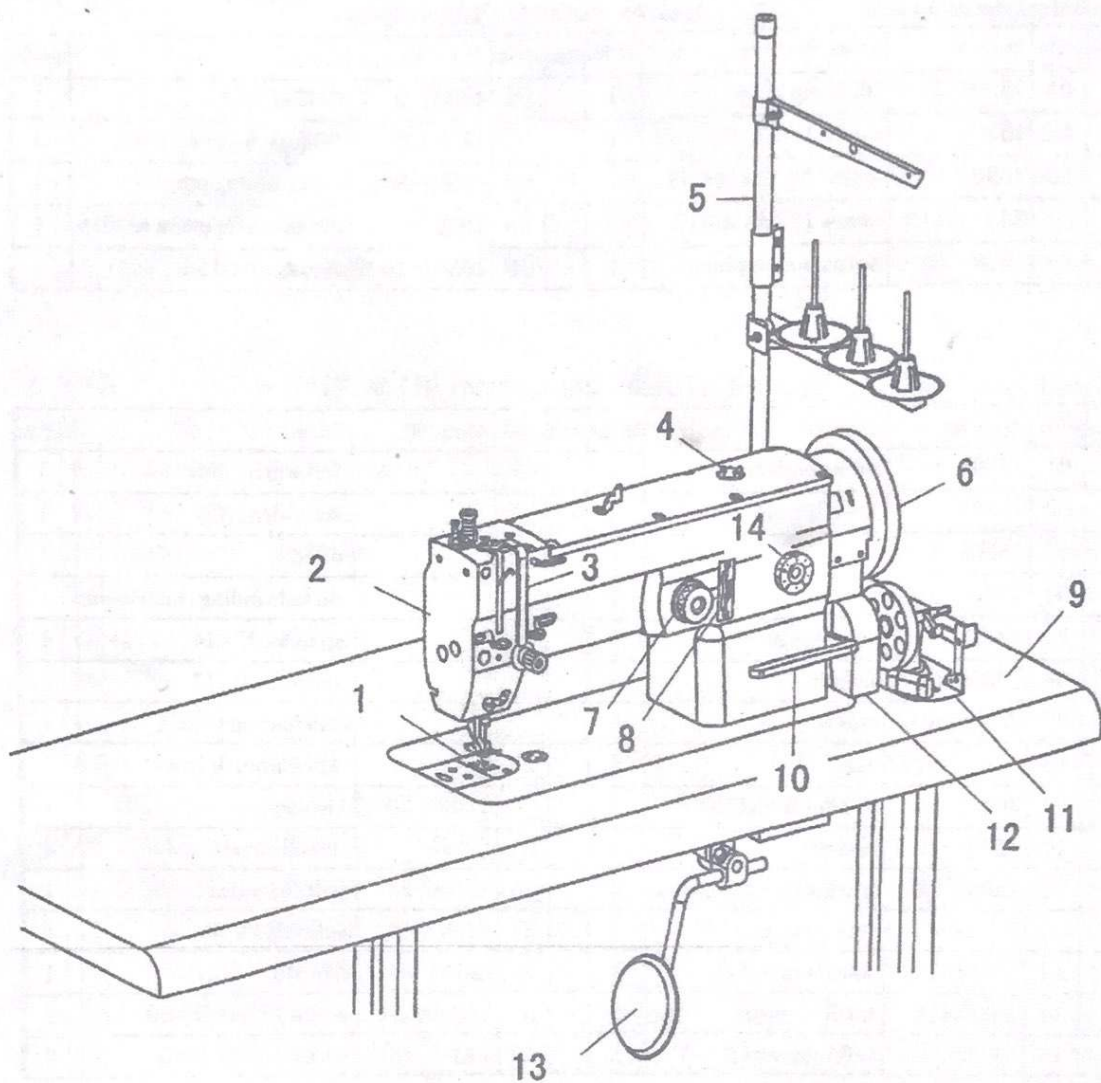

- | | | |
|---------------------------|---------------------------|------------------------|
| 1. 针板 | 2. 面板 | 3. 挑线杆防护罩 |
| 4. 油窗 | 5. 线架 | 6. 手轮 |
| 7. 摆幅手转轮 | 8. 摆幅指示板 | 9. 台板 |
| 10. 抬押扳手 | 11. 绕线器 | 12. 皮带罩 |
| 13. 膝控碰块 | 14. 针距标盘 | |
| 1. needle plate | 2. panel | 6. stitch-scaff shield |
| 4. oil screen complete | 5. thread stand | 6. upper wheel |
| 7. stitch wide hand wheel | 8. stitch wide show plate | 9. table |
| 10. spanner | 11. thread-winding | 12. hand wheel cover |
| 13. knee lifter complete | 14. dial number | |

二、缝纫机规格 two、sewing machine specification

机种model 项目item	1530	2530
速度 sewing speed	2000spm	2000spm
针摆幅度 stitch width	2点 2 points	2点 2 points
使用机针 needle	Dpx5	Dpx17
挑线杆活动量 take-up thread stroke	73	73
针杆活动量 needle bar stroke	34	34
压脚差动量 presser walking distance	-	3-7mm
压脚步上升量 presser foot lift	7mm	7mm
使用旋梭 hook	卧式大旋梭horizontal hook(large)	卧式大旋梭horizontal hook(large)
用途 application	薄料-中料light-middle	中料-厚料middle-heavy

三、安装installation

1. 油盘

如图 (1) 所示, 将油盘①放入台板。

1. oil disk
(see figure 1)

Fix the oil disk to the table.

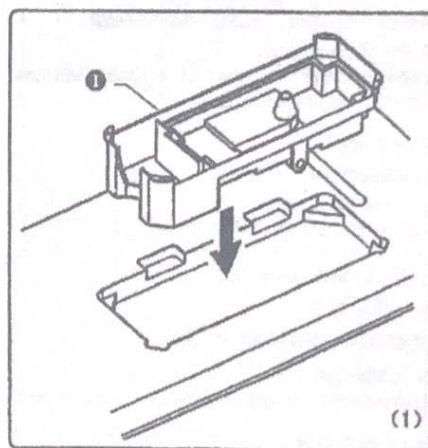

2. 膝控碰块

如图 (3) 所示, 将膝控碰块①插入油盘上的膝控提升连杆②。松开螺钉③和螺钉④, 将膝控碰块①移至易于使用的位置。

2. knee-control component
See figure 2

Place the knee lifter assembly onto the knee lifter bar on the oil pan. Loosen the screw (3) and (4), and adjust the knee lifter assembly (1) to the suitable position.

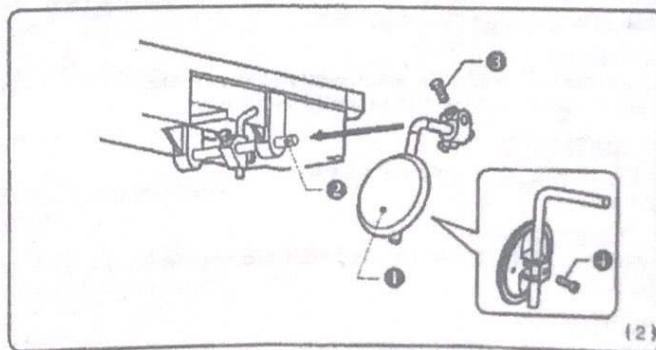

如图(2)所示

3. 机壳铰链套

将两个机壳铰链套①嵌入台板的止动销,并用两个铁钉②将其固定。

See figure 3

3. rubber cushions

Insert the two rubber cushions 1 into the notches in the work table, and then secure them with the two nails 2.

4. 三角型防震垫块

将两个三角型防震垫块③放入油盘的两角,然后用两个铁钉④将其固定。

4. Triangle Shock Pad

insert the two Triangle Shock Pad into the two side of the oil pan, and then secure them with the two nails 4.

5. 耳型防震垫块

将两个耳型防震垫块⑤放入油盘的另外两角,并用两个铁钉⑥将其固定。

5. ear Shock Pad

insert the two ear Shock Pad into the two side of the oil pan, and then secure them with the two nails 6.

6. 膝控提升顶杆

膝控提升顶杆⑦插入油盘。

6. knee lifter complying bar

Insert the knee lifter complying bar 7.

如图(4)所示 See figure 4

7. 缝纫机头部

将铰链①插入机壳,然后放入机壳铰链套②。

7. The machine head

Insert the hinge 1 onto the machine head, and then onto the rubber cushion 2.

8. 机头撑杆

将机头撑杆③敲入台板中。

8. Pillow of the head

Tap the pillow 3 into the table hole.

如图(5)所示 See figure 5

9. U型皮带罩

用螺钉②将U型皮带罩①锁入机壳。

9. U type belt cover

Use the screw 2 to fix the U type belt cover 1 to the machine head.

10. C型皮带罩

用螺钉④将C型皮带罩③锁入机壳。

用螺钉⑤将C型皮带罩③与U型皮带罩①锁紧。

10. C type belt cover

Use the screw 4 to fix the C 3 type belt cover to the machine head. Use the screw 5 to tighten the C type and U type belt cover.

11. 三角型皮带罩

用螺钉⑦和螺母⑥将U型皮带罩与三角型皮带罩⑥锁紧。

11. Triangle belt cover

Tighten the U type belt cover and Triangle belt cover by screw 7 and nut 8.

12. D型皮带罩

将D型皮带罩⑨扣入D型皮带罩⑩。

12. D type belt cover

Insert the D type belt cover into the D type belt.

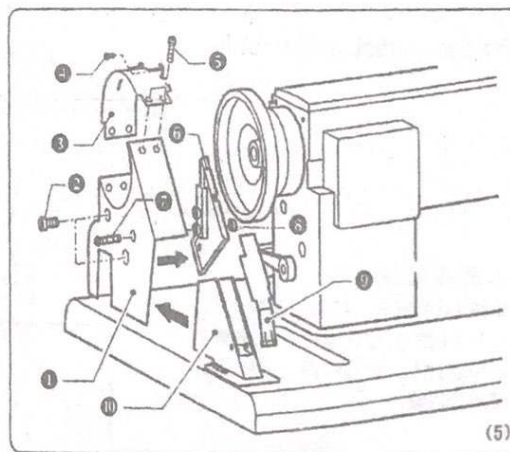
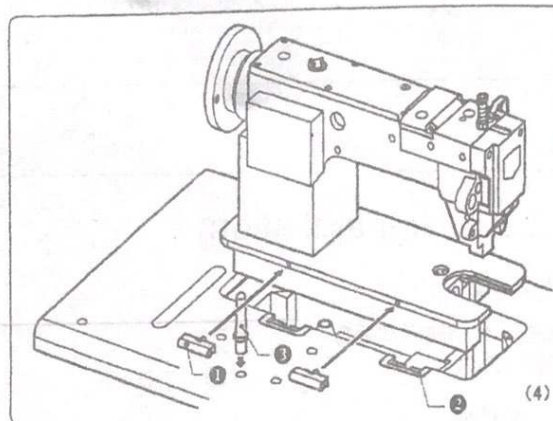
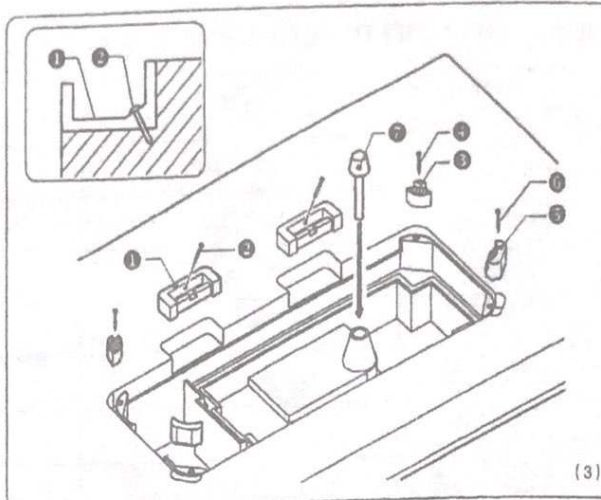

四、调整 Four、adjust

1. 缝纫机针的安装

<1530>

如图(6-1)所示,转动手轮使针杆上升到最高位置,松开机针紧固螺钉②,将机针①插到顶,针凹面向A方向,然后拧紧螺钉②。

1. Installing the needle

<1530>

See figure(6-1), Turn the machine pulley to move the needle bar to its highest position.

Loosen the screw 2, hold the needles 1 with their groove facing inward, insert them all the way into the needle bars. And retighten the screws 2.

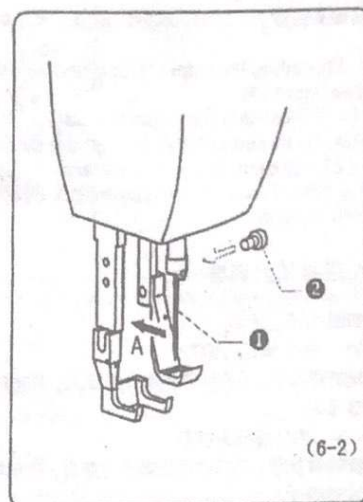
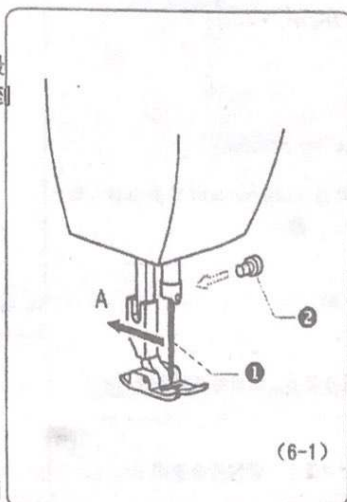

<2530>

如图(6-2)所示,转动手轮使针杆上升到最高位置,松开机针紧固螺钉②,将机针①插到顶,针凹面向A方向,然后拧紧螺钉②。

<2530>

See figure(6-2), Turn the machine pulley to move the needle bar to its highest position.

Loosen the screw 2, hold the needles 1 with their groove facing inward, insert them all the way into the needle bars. And retighten the screws 2.

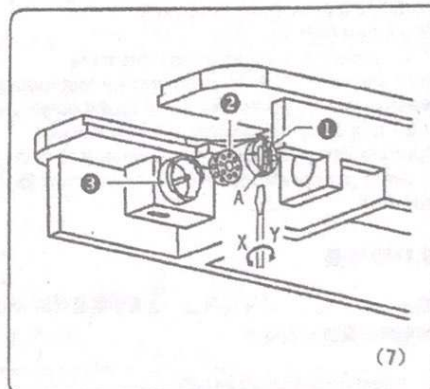

2. 梭壳拆装及张力调整

如图(7)所示:

2. removing the cap and adjust the tension.

See figure(7)

<1> 梭壳的拆装

掰开梭壳盖,即可取出梭壳①。将梭芯②装入梭壳①后,掰开梭壳盖,讲梭壳扣入旋梭③,并与之结合即可。

<1> Removing the cap

Pull the puller of the cap and take out the cap, insert the bobbin into the cap. Insert the cap into the rotary hook.

<2> 底线张力的调整

如图,用螺丝刀转动螺钉A, X方向底线张力变小, Y方向张力变大。

<2> adjust the tension of the bottom thread

See figure, use screwdriver turn screw A, X direction less tension, Y direction more tension.

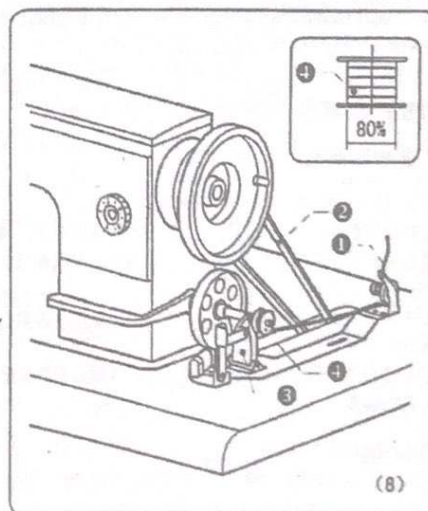

3. 绕底线 Winding the lower thread

底线①按图(8)所示连接好之后,推动绕线器③的扳手使转轮贴到皮带②上,并随之转动。梭芯④上的绕线量约80%时为最好。

After connected the lower thread 1 as pic see figure 8, push the spanner of the thread winding 3, make is attached to the belt and run with it.

The thread of the bobbin full with 80% is the best.

4.穿面线及调整

如图(9)所示

<1> 穿面线

面线①按图依次穿过。

<2> 面线的调整

转动夹线器②, X方向面线张力变大, Y方向张力变小。

4. Threading the upper thread and adjust

See figure (9)

(1) Threading the upper thread

Pull the thread out and through the place as the picture.

(2) adjusting the thread surface

Turn the thread-running plate(2), X direction is more tension, Y direction is less tension.

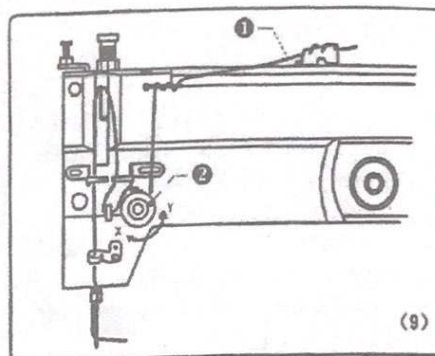

5.压脚压力调整

如图(10)所示

<1> 外压脚压力调整

旋转螺丝①, A方向外压脚压力变大, B方向压力变小, 调整后必须用好螺母②。

<2> 内压脚压力调整

旋转螺丝③, C方向内压脚压力变大, D方向压力变小。调整后必须固好螺母④。

5. adjusting presser foot pressure

See figure (10)

(1) adjusting out presser foot pressure

Turn the screw 1, A direction presser foot more pressure, B direction presser foot less pressure, must fix the screw 2 after well adjusted.

(2) adjusting inside presser foot pressure

Turn the screw 3, C direction presser foot more pressure, D direction presser foot less pressure, must fix the screw 4 after well adjusted.

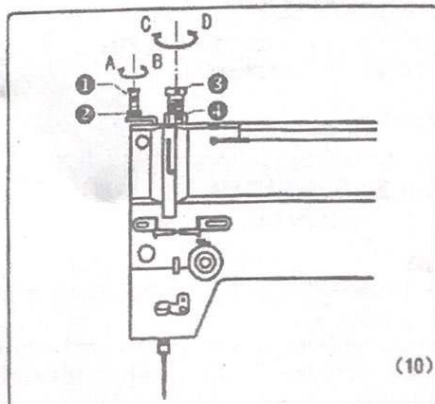

6.针距调整

如图(11)所示。针距调节盘①上表示的是针距mm的数值, 左右转动调整到自己需要的数值上。

6. adjusting the stitch length

See figure (11)

The feed regulating dial is show stitch length (mm), can turn left or right to match your request.

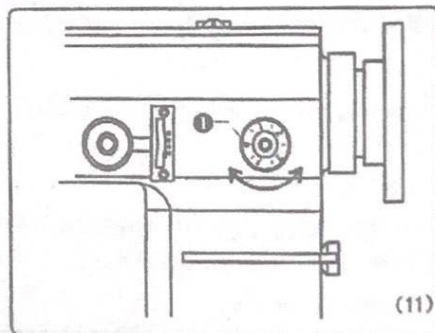

如图(12)所示。

7.送布牙高度及倾斜度调整

<1> 送布牙高度调整

松开拾牙曲柄①上的螺钉②, 上下运动拾牙曲柄①, 即可调整送布牙③的高度。转动手轮, 当送布齿上升最高时, 针板表面与送布牙尖距离为1.0-1.2mm时最标准。

<2> 送布牙倾斜度调整

松开牙架曲柄④上的螺钉⑤后, 用螺丝刀旋转牙架偏心轴⑥, 对送布牙③的倾斜度进行调整。

调整送布牙③的倾斜度后, 送布牙③的高度也会有所变化, 所以请再进行送布牙高度的调整。

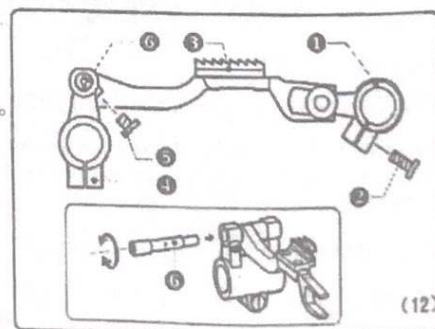

See figure (12):

7. adjusting the height of feed dog and Tilt

(1) adjusting the height of feed dog

Loosen the screw of 1, raise or lower the tooth crank to adjust the height of the feed dog. Turn the pulley until the feed dog rises to the highest position.

So the feed dog will rise to about 1.0-1.2mm above the needle plate is the best.

(2) adjusting the tilt of feed dog

Loosen the screw of 5, turn the shaft 6 to adjust the tilt of the feed dog.

After adjusted, the height of the feed dog also changed, so need to readjust the height of the feed dog.

如图(13)所示

8. 摆幅调整

<1> 粗调

摆幅指示板②上表示的是摆幅mm的数值, 转动摆幅手转轮①, 可粗略调整摆幅, A方向减小, B方向摆幅增大。

<2> 微调

打开橡皮塞③, 用螺丝刀旋转偏心肖④, 对摆幅偏左偏右进行细微调整。

See figure (13)

8. Stitch width adjustments

<1> Coarse

Sewing dashboard ② shows the value of sewing (mm), turn the hand wheel, can adjust the stitch width roughly, A direction decreases, B direction of the sewing increases.

<2> fine tuning

Open the rubber ③, Use a screwdriver to rotate the eccentric Shaw ④, Adjust the stitch width on the left-right slightly.

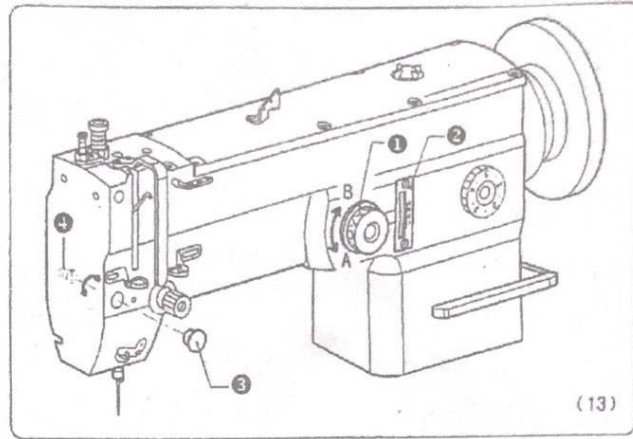

五、故障原因及对策 Five, Trouble causes and solutions

NO	故障状态 Fault Status	查看事项 View Matters	故障原因 cause of issue	处理方法 Approach
1	断针 broken needle	针的方向、高度 Direction of the needle、height	上针方向不对 The needle in the wrong direction	正确方向上到最上 To the upper right direction
		针的方向、高度 Direction of the needle、height	弯针 Looper	换针 Change needle
		送布牙行程 Feed dog stroke	针杆运行与送布行程不对 Needle bar does not run with the feed stroke	调整送布牙行程 Adjust the feed dog stroke
		针杆上升量 The needle bar lift amount	针和旋梭的行程不良 Needle and hook bad trip	调整送布牙行程 Adjust the feed dog stroke
		针杆高度 Needle bar height	针和旋梭的行程不良 Needle and hook bad trip	调整送布牙行程 Adjust the feed dog stroke
		针和旋梭主距离 Needle and bobbin main distance	针和旋梭的行程不良 Needle and hook bad trip	调整送布牙行程 Adjust the feed dog stroke
2	断线 broken thread	穿线方法 Threading method	穿线出错 Threading Error	正确方法穿线 The correct way threading
		缝纫针 Sewing needle	针已弯或针尖已坏 Needle tip has been bent or broken	换针 Change needle
		针的方向、高度 Direction of the needle、height	上针位置不良 Bad position on the needle	正确方向上针 The needle in the right direction
		面线张力 Upper thread tension	面线张力太强 Upper thread tension is too strong	调整面线张力 Adjusting the thread tension
		底线张力 The bottom line tension	底线张力太强 The thread tension is too strong	调整底线张力 Adjust the bottom line tension
		挑线弹簧运动量 The thread spring exercise	运动量太大 Too much exercise	调整弹簧的运动量 Adjusting spring exercise
3	线路不良 bad line	挑线弹簧张力 The thread tension spring	挑线簧张力太弱 Pick-up spring tension too weak	调整挑线簧张力 Adjust the spring tension of the thread
		线张力 Thread tension	底、面线张力不良 Bottom, upper thread tension is bad	调整底、面线张力 Adjust the bottom thread tension
		挑线簧张力 The thread tension spring	挑线簧张力不良 Bad the thread tension spring	调整挑线簧张力 Adjust the thread tension spring
		压脚 Presser	压脚太高 Presser foot too high	调整压脚高度 Adjust the presser foot height
		压脚压力 The pressure of presser foot	压脚压力太小 The pressure of presser foot is too small	调整压脚压力 Adjust the presser foot pressure
		送布牙高度 Feed dog height	送布牙高度太低 Feed dog height is too low	调整送布牙高度 Adjust the feed dog height
4	线缝零乱 Stitch disorder	压脚压力 The pressure of presser foot	压脚压力太小 The pressure of presser foot is too small	调整压脚压力 Adjust the pressure of presser foot
		梭芯 Bobbin	梭芯有划痕 Bobbin scratches	打磨光滑或更换 Polished smooth or replace
		V型皮带张力 V-belt tension	皮带张力太小 Belt tension is too small	调整皮带张力 Adjust the belt tension
		面线张力 Upper thread tension	面线张力太强 Upper thread tension is too strong	调整面线张力 Adjusting the thread tension
5	缝料皱褶 Sewing material fold	底线张力 The bottom line tension	底线张力太强 The thread tension is too strong	调整底线张力 Adjust the bottom line tension
		挑线簧张力 The thread tension spring	挑线簧张力不良 Bad the thread tension spring	调整挑线簧张力 Adjust the thread tension spring
		挑线簧运动量 Vaulting box spring exercise	运动量太大 Too much exercise	调整弹簧的运动量 Adjusting spring exercise
		压脚压力 The pressure of presser foot	压脚压力太小 The pressure of presser foot is too small	调整压脚压力 Adjust the pressure of presser foot
6	底线纠结 The bottom line tangled	梭芯 Bobbin	拉出底线时, 梭芯反转 Pull the bottom line, reverse the bobbin	反向安装梭芯 Reverse the bobbin
		梭芯 Bobbin	梭芯转动不流畅 Bobbin is not turning smoothly	更换梭芯 Replace the bobbin
		梭芯绕线量 Bobbin winding amount	绕线量过多 Excessive amount of winding	绕线量不超过80% Limit of no more than 80%